

T.E.(ELECTRONICS & TELE-COMMN.)(Sem VI) (CBSGS) COMPUTER COMMUNICATION AND TELECOM NETWORKS

Q.P. Code : 34633

[Time: Three Hours]

[Marks:80]

Please check whether you have got the right question paper.

- N.B:
1. Question No.1 is compulsory.
 2. Solve any three out of remaining five questions.
 3. Draw neat diagram if necessary.
 4. Assume suitable data wherever required.

- Q.1 Attempt any four out of five 20
- a) What is framing? How frames can be classified?
 - b) A pure ALOHA network transmits 200 bit frames on a shared channel of 200 kbps. What is the throughput if the system (all stations together) produces:
 - (i) 1000 frames per second
 - (ii) 500 frames per second
 - (iii) 250 frames per second
 - c) Explain Three-Way Handshaking for connection establishment in TCP
 - d) What is the subnetwork address if the destination address is 200.45.34.56 and the subnet mask is 255.255.240.0?
 - e) Differentiate between Bus Topology and Ring Topology
- Q. 2 a) Explain OSI model. Consider a source, destination machine and some intermediate nodes for the discussion. 10
- b) (i) Differentiate between TDM and FDM 5
 - (ii) Explain various addresses used in TCP/IP Layered Architecture. 5
- Q. 3 a) What is DSL Technology? List different DSLs available. Discuss salient features of ADSL 10
- b) Explain CSMA/CD in detail and also mention its use. 10
- Q.4 a) Draw and explain TCP Header format. 10
- b) What is sliding window protocol? Explain Stop and Wait ARQ in detail. 10
- Q.5 a) Using the below figure, apply the Bellman-Ford algorithm to find both the minimum cost from each node to the destination node (assume node F) and the next node along the shortest path. Also draw the tree diagram. 10

Q.P. Code : 34633

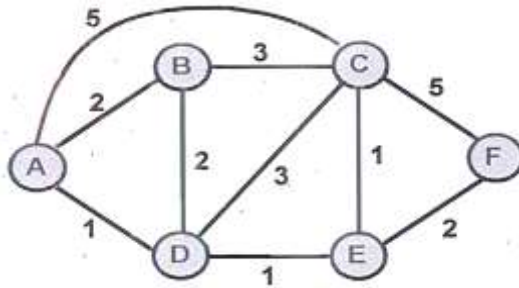

b) Define Classful addressing scheme used in IPV 4. What is a mask and range of addresses used for 10 each class?

Q.6 Write a short notes on (any two):

20

- a) HFC
- b) ATM
- c) DNS

- N.B.: (1) Question No 1 is Compulsory.
 (2) Attempt any three questions out of remaining five.
 (3) All questions carry equal marks.
 (4) Assume Suitable data, if required and state it clearly.

1. Attempt any Four:-

- (a) Derive an expression for Entropy 05
 (b) Explain linearity and cyclic property of cyclic code. 05
 (c) How is spread spectrum signal different from normal signal? 05
 (d) Compare: Binary phase shift keying and binary frequency shift keying. 05
 (e) Write short note on equalizers? 05

2. (a) A discrete memoryless source has an alphabet of seven symbols with probabilities for its output as described in Table 10

Symbol	S ₀	S ₁	S ₂	S ₃	S ₄	S ₅	S ₆
Probability	0.25	0.25	0.125	0.125	0.125	0.0625	0.0625

Compute the Huffman code for this source moving the “combined” symbol as high as Possible. Explain why the computed source code has an efficiency of 100 percent.

- (b) Explain the necessity of line codes for data transmission. State different types of Line codes. 10
3. (a) Explain in detail 16-QAM Transmitter and receiver system. Also draw Signal constellation diagram for 16 QAM in detail. 10
- (b) Calculate the error probability of matched filters. 10
4. (a) Explain the working of QPSK system with neat block diagrams. 10
- (b) The Parity check matrix of particular (7,4) linear block code is given by : 10

$$H = \begin{bmatrix} 1 & 1 & 1 & 0 & 1 & 0 & 0 \\ 1 & 1 & 0 & 1 & 0 & 1 & 0 \\ 1 & 0 & 1 & 1 & 0 & 0 & 1 \end{bmatrix}$$

1. Find the generator matrix (G).
 2. List all code vectors.
 3. What is the minimum distance between the code vectors?
 4. How many error can detected? How many can be corrected?

TURN OVER

5. (a) Encode the message 101 in systematic form using polynomial division and the generator $g(X) = 1 + X + X^2 + X^4$ 10
- (b) For the given code show in figure obtain the convolutional code for the bit sequence 1 1 0 1 1 0 1 1 and decode it by constructing the corresponding code tree. 10

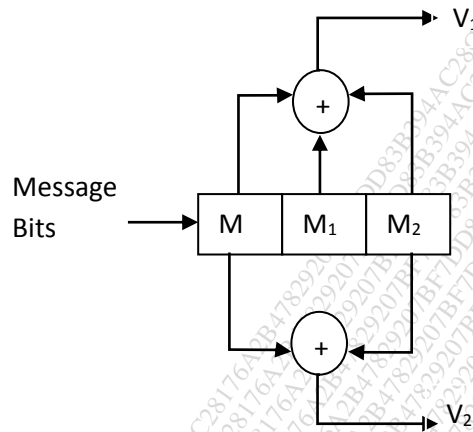

6. (a) Draw the block diagram for FH-SS system and explain the working. Differentiate between slow frequency hopping and fast frequency hopping. 10
- (b) Draw the block diagram of MSK transmitter. Why MSK is called shaped QPSK. 10

Time: 3 Hours

Marks: 80

- N.B: (1) Questions No.1 is compulsory.
 (2) Attempt any three questions out of remaining five questions.
 (3) Assume suitable data if required.
 (4) Figures to the right indicate full marks.

Q 1. Solve any four

- a) Determine the zeros of the following systems and indicate whether the system is minimum, maximum or mixed phase. 5
- 1) $H_1(z) = 6+z^{-1}+6z^{-2}$
 - 2) $H_2(z) = 1-z^{-1}-6z^{-2}$
- b) Define group delay and phase delay. 5
- c) Compare FIR and IIR filters 5
- d) What is frequency warping in bilinear transformation. 5

Q2 a) Compute DFT of sequence $x(n) = \{ 2, 1, 2, 1, 1, 2, 1, 2 \}$ using DIT-FFT algorithm. 10

b) A low pass filter is to be designed with following desired frequency response.

$$H_d(e^{j\omega}) = \begin{cases} e^{-j2\omega} & -\frac{\pi}{4} < \omega < \frac{\pi}{4} \\ 0 & \frac{\pi}{4} < \omega < \pi \end{cases}$$

Determine the filter coefficients $h_d(n)$ if the window function is defined as

$$w(n) = \begin{cases} 1 & 0 \leq n \leq 4 \\ 0 & \text{otherwise} \end{cases}$$

Also determine the frequency response $H(e^{j\omega})$ of the designed filter. 10

Q 3 a) The transfer function for discrete time system is given as

$$H(z) = \frac{1 + \frac{1}{2}Z^{-1}}{1 - \frac{3}{4}Z^{-1} + \frac{1}{8}Z^{-2}}$$

- i) Draw Direct Form I and Form II realization 10
 - ii) Draw cascaded and parallel form realization
- b) Explain subband coding of speech signal as an application of multirate signal processing. 10

Q4 a) Develop composite radix DITFFT flow graph for $N=6=2 \times 3$. 10

b) Design a digital Butterworth filter that satisfies following constraints using bilinear transformation method. Assume $T_s=1s$.

$$0.9 \leq |H(e^{jw})| \leq 1 \quad 0 \leq w \leq \frac{\pi}{2}$$

$$|H(e^{jw})| \leq 0.2 \quad \frac{3\pi}{4} \leq w \leq \pi$$
10

Q 5 a) Show the mapping from S plane to Z plane using impulse invariant method. Explain its limitations. Using this method determine $H(z)$ if

$$H(s) = \frac{10}{(s+5)(s+2)} \quad \text{if } T_s=0.2s.$$
10

b) If $x(n)=\{1,2,3,\}$ and $h(n)=\{1,0\}$

- 1) Find linear convolution using circular convolution
 - 2) Find circular convolution using DFT-IDFT.
- 10

Q6 Write short notes on following,

- a. Musical Sound Processing. 07
- b. Dual tone multi frequency signal detection. 06
- c. Subband Coding of Speech signals. 07

(3 Hours)

- N.B: (1) Questions No.1 is compulsory.
 (2) Solve any three questions out of remaining
 (3) Draw neat labeled diagram whenever necessary
 (4) Assume suitable data if necessary

Q1. Answer any 4 questions from the given questions:

5x4

- Describe fuzzy inference system with neat block diagram.
- What is the role of Dendrites, Soma and Axon of biological neuron that led to the concept of artificial neuron? Brief with a diagram.
- Discuss how momentum factor accelerates training of perceptron neural network.
- Explain memorization issue in neural networks. How to avoid memorization and get generalization?
- What is λ -cut set? Brief with an example

Q2.a. If one of the weights is removed from Multilayer Perceptron Neural Network (MLP NN) the functionality of the network is highly affected whereas Radial Basis Function Neural Network (RBF NN) functionality is not significantly affected. Justify. Also, discuss how pattern separation in RBF NN happens by placing hyper-ellipsoids and hyper-sphere whereas in MLP NN it happens due to hyper-planes.

8

b. What are the merits of fuzzy controllers over conventional controllers?

4

c. i) Using max-min composition find relation between R and S

8

$$R = \begin{matrix} & y1 & y2 & y3 \\ x1 & \begin{bmatrix} 1 & 1 & 0 \end{bmatrix} \\ x2 & \begin{bmatrix} 0 & 0 & 1 \end{bmatrix} \\ x3 & \begin{bmatrix} 0 & 1 & 0 \end{bmatrix} \end{matrix}$$

$$S = \begin{matrix} & z1 & z2 \\ x1 & \begin{bmatrix} 0 & 1 \end{bmatrix} \\ x2 & \begin{bmatrix} 1 & 0 \end{bmatrix} \\ x3 & \begin{bmatrix} 1 & 1 \end{bmatrix} \end{matrix}$$

ii) Consider the following fuzzy sets

$$A = \left\{ \frac{0.8}{10} + \frac{0.3}{15} + \frac{0.6}{20} + \frac{0.2}{25} \right\}$$

$$B = \left\{ \frac{0.4}{10} + \frac{0.2}{15} + \frac{0.9}{20} + \frac{0.1}{25} \right\}$$

Calculate the Demorgan's law

$$\overline{A \cup B} = \overline{A} \cap \overline{B} \text{ and } \overline{A \cap B} = \overline{A} \cup \overline{B}$$

- Q3.a. Describe any two methods for feature extraction of handwritten characters. Also, explain handwritten characters classification using supervised neural network? 10
- b. Describe the application of fuzzy logic for following image processing operations: 10
- a) Image Contrast Enhancement
 - b) Image Smoothing
- Q4.a Explain pattern recovery using discrete Hopfield network. 10
- b. Explain Kohonen self-organizing network for pattern clustering. Also, explain its learning algorithm. 10
- Q5.a Explain the purpose of de-fuzzification process? Discuss any three techniques for de-fuzzification. 10
- b. Explain with neat diagram the radial basis function neural network for function approximation. 10
- Q6.a. Describe with architecture Learning Vector Quantization (LVQ) network with suitable diagram and the flow chart for pattern classification. 10
- b. What is the role of a) weights b) bias c) activation function d) training data set and e) validation data sets in the context of neural networks 10
-

[Time: Three Hours]

[Marks:80]

Please check whether you have got the right question paper.

- N.B:
1. Question.No.1 is compulsory.
 2. Attempt any **three** questions from remaining **five** questions.
 3. Make suitable assumptions wherever necessary and state them **clearly**.

- Q1 a) Define a file system. What are various components of a file system? State and explain commonly used operations on file. 5
- b) What is the difference between a system call and an interrupt? 5
- c) Give memory partition of 100K,500K,200K,300K and 600K(in order).How would each of the first 5 fit, best fit and worst fit algorithm place process of 212k,417k,112k,and 426k(in order)? Which algorithm makes the most efficient use of memory? 5
- d) Write four optimizing criteria for CPU scheduling. 5
- Q.2 a) Consider the following page reference string A,B,C,D,B,A,E,F,A,B,C,G,F,C,F. How many page faults would occur for the following page replacement algorithm assuming three and four frames? Remember all frames are initially empty: 10
- FIFO
 - Optimal
 - LRU
- b) Justify the need for process synchronization & Design a solution for producer consumer problem using semaphore. 10
- Q.3 a) Consider the following snapshot of the process to be executed. Draw the Gantt chart and determine the average. waiting time and average turnaround time for FCFS, SJF(non-preemptive) and round robin (quantum=2) scheduling algorithm. 10

Process	Arrival Time	Burst Time
P1	0	4
P2	2	5
P3	4	6
P4	5	2

b) Consider the following snapshot 10

Process	Allocation	Max	Available
	A B C D	A B C D	A B C D
P0	0 2 1 2	0 3 2 2	2 5 3 2
P1	1 1 0 2	2 7 5 2	
P2	2 2 5 4	2 3 7 6	
P3	0 3 1 2	1 6 4 2	
P4	2 4 1 4	3 6 5 8	

Answer the following using Banker's algorithm.

- What is the content of matrix Need?
- Is the system in the safe state?
- If the request from process P1 arrives for (1,3,2,1) can request be granted immediately?

- Q.4 a) Suppose the head of moving-head disk with 200 tracks, numbered 0 to 199 is currently serving 10 a request at track 143 and has just finished a request at track 125. If the queue of requests is kept in the FIFO order 86,147,91,177,94, 150, 100, 175, 130 What is total head movement to satisfy these requests for the following disk scheduling algorithms? i) FCFS ii) SSTF iii) C-SCAN 10
- b) Explain working of EDF and RMA real-time scheduling algorithms. 10
- Q.5 a) What is the virtual memory? Explain with neat diagram the translation of virtual address into physical address in a segmentation/paging system. 10
- b) Explain process management in Linux. 10
- Q.6 a) State and explain the necessary conditions that lead to deadlock situation. 10
- b) Explain how LINUX performs file management. 10

(3 Hours)

(Total Marks: 80)

Please check whether you have the right question paper.

- N.B.:**
- 1) Question No.1 is compulsory.
 - 2) Answer any Three out of remaining five questions
 - 3) Draw the neat diagrams wherever necessary.
-
1. (a) Explain frame rate and refresh rate in digital TV **05**
 - (b) Explain when and why the horizontal sweep oscillator step out of synchronism. **05**
 - (c) Give CCIR-B standards. **05**
 - (d) Explain merits and demerits of LED display. **05**
 2. (a) Draw and explain Horizontal sync details compared to horizontal deflection sawtooth wave. **10**
 - (b) Explain D2-MAC packet format and state D2-MAC characteristics. **10**
 3. (a) Why are serrations needed in vertical sync pulses and how it solves the problem of half-line discrepancy? Explain with diagram. **10**
 - (b) Draw and explain Image orthicon camera tube. What is the function of the electron multiplier section? **10**
 4. (a) Draw and explain NTSC decoder along with the explanation for phasor diagrams of the signals in the NTSC system. **10**
 - (b) Explain MAC signals its compression technique and scanning frequency. **10**
 5. (a) Explain with diagram wide dimension HDTV. **10**
 - (b) What is the need of MUSE system? Explain its technical specifications, advantages and disadvantages. **10**
 6. Write short notes on (any two):-- **20**
 - (a) EBU MAC system
 - (b) VSB transmission for TV, how much frequency is allocated for attenuation slope and why?
 - (c) Sync pulse separation and generation of vertical and horizontal sync pulses.

(२घंटे)

(कूल अंक: ३५)

१. वाचन आकलन को बढ़ाने के लिए विभिन्न तकनीकों को स्पष्ट कीजिए। (१०)
२. कक्षा में प्रवचन कि संरचना का महत्व स्पष्ट कीजिए। (१०)
३. “भारतीय कक्षा में सामाजिक भाषायी जागरूकता का विकास शिक्षक कर सकता है” सोदाहरण स्पष्ट कीजिए। (१०)
४. “चर्चा आधारित अध्ययन शाखांतर्गत भाषा का संवर्धन करने में मदद करती है” समर्थन कीजिए। (१०)
५. स्क्रीनर और चोम्स्की के भाषायिक अधिग्रहण उपपत्ति के बीच में अंतर स्पष्ट कीजिए। (१०)
६.
 - अ) व्यवहार और चिंतनशील पाठ के आशय में अंतर (५)
 - ब) शिक्षा में घाटे कि उपपत्ति (५)
 - क) भारतीय बहुभाषावाद कि प्रकृति (५)

(P.T.O)

(रतास)

(एकूण गुण :३५)

१. वाचन आकलन वृद्धिंगत करण्याची विविध तंत्रे विशद करा. (१०)
२. वर्गात व्याख्यानाची संरचनेचे महत्व स्पष्ट करा (१०)
३. “भारतीय वर्गात सामाजिक भाषिक जाणीवेचा विकास शिक्षिका करू शकतात” सोदाहरण स्पष्ट करा. (१०)
४. “चर्चा आधारित अध्ययन शखांतर्गत भाषेच्या विकासाचे संवर्धन करण्यात सहाय्य करते”. (१०)
समर्थन करा.
५. स्कीनर आणि चोमस्की च्या भाषा संपादन उपपत्ती मध्ये फरक स्पष्ट करा. (१०)
६. अ) व्यवहार आणि चिंतनशील मजकूर मधील फरक (५)
ब) शिक्षणातील तूट उपपत्ती (Defecit Theory) (५)
क) भारतीय बहुभाषिकतेचे स्वरूप (५)

Sem VI Expt, Dec-18
(CBWS.)

19/12/18

Time: 3 Hours

Marks: 80

- 1] Question no.1 is compulsory
- 2] Attempt any three questions out of remaining questions
- 3] Assume suitable data if required
- 4] Figures to the right indicate marks.

Q. No. 1) Attempt any four from the following

[20]

- a) Draw VTC curve of static CMOS inverter and show all critical voltages (V_{IL} , V_{IH} , V_{OL} , V_{OH} , and V_{INV}) on the plot. Also show current drawn by CMOS inverter on VTC.
- b) Explain any two short channel effects in MOS transistor.
- c) What are advantages and disadvantages of dynamic CMOS logic circuit?
- d) Implement 4:1 multiplexer using NMOS pass transistor logic.
- e) Explain different CMOS clocking styles.

Q. No. 2)

- a) Consider a CMOS inverter circuit with the following parameters:

$$V_{DD} = 3.3V$$

$$V_{t0,n} = 0.6V$$

$$V_{t0,p} = -0.9V$$

$$K_n = 200 \mu A/V^2$$

$$K_p = 80 \mu A/V^2$$

Calculate noise margins of the circuit. Consider $K_R = 2.5$.

[10]

- b) Implement $Y = \overline{A(B+C)(D+E)}$ using

- (i) static CMOS logic style
- (ii) Dynamic logic
- (iii) Depletion load logic
- (iv) Pseudo-NMOS logic

[10]

Q. No. 3)

- a) Explain in detail the fabrication sequence of NMOS transistor with cross sectional view of each step.

[10]

- b) Draw schematic of six transistor SRAM cell. Describe various constraints that should be imposed on the devices to guarantee safe read and write operation. Also discuss relative sizing of the transistors in the cell. [10]

Q. No. 4)

- a) Define scaling. Explain different types of scaling. [10]
- b) Construct a full adder mirror circuit and compare the structure with direct static CMOS circuit. [10]

Q. No. 5)

- a) What are different types of design rules? Draw layout of two input CMOS NAND gate as per lambda based design rules (show units in lambda). [10]
- b) Explain in detail static and dynamic power dissipation. What are the main components which make power dissipation in CMOS circuit? [5]
- c) What is clock skew? Explain clock distribution technique in VLSI system. [5]

Q. No.6) Write short notes on any FOUR [20]

- i) ESD protection circuit.
- ii) 4x4 Barrel shifter
- iii) Latch up
- iv) 3-T DRAM
- v) Decoder in memory structure
